

# Rabbit



**CONVERTIBLE**

IF YOU GRADE THE RABBIT CONVERTIBLE,  
REMEMBER THAT NEATNESS COUNTS.

## AND THIS CAR IS NEAT.

First impressions count, too, and one look at the Rabbit Convertible lets you know how much fun driving it can be. The Rabbit Convertible seats four with the top up or down, and everybody has their own speaker. (Actually, it's a four-speaker stereo system — new for '82). The back seat is newly styled for greater comfort and to be even more attractive to those waiting to hop in.

The real beauty, though, is how the Rabbit Convertible has benefited from over a decade of solid engineering and development. There's Volkswagen's front wheel drive technology for excellent directional control, impressive braking performance and responsive steering — in an extensively modified unit-steel body.

This year Volkswagen's even come up with a new way to help you develop good driving habits when you require limited power: it's part of our Formula E program. Every model with a manual transmission has a unique upshift light that tells you when you can save gas by shifting into a higher gear. Naturally, you can override this feature when you need to accelerate quickly.

It's just another good reason to give the Rabbit Convertible top marks.



**Nothing else is a  
Volkswagen.**



Volkswagen of America, Inc. believes the specifications in this brochure to be correct at the time of printing; however, specifications, standard equipment and options are subject to change without notice. Some options may not be available in all areas. Please check with your dealer for details and verify that your car includes the optional equipment you ordered.

THE RABBIT CONVERTIBLE'S  
INCLUDING PASSING



D.

# PERFORMANCE CAN BE DEMONSTRATED IN MANY WAYS, AN EXTRAORDINARY NUMBER OF GAS STATIONS.\*

You expect a Volkswagen to be fuel efficient, and this one is. But the Rabbit Convertible is efficient in every which way — particularly when it comes to performance.

Up front is where the car enthusiast's heart lies. That's where the fuel injected, overhead cam engine pumps 74 horsepower into the five-speed, Formula E transmission, and then (with smoothness and effectiveness) to the drive wheels.

To monitor the engine's performance a full set of gauges is standard. There's a special padded steering wheel to direct the rack and pinion system along favorite roads and power-assisted front disc brakes designed to deliver safe, sure stops.

Steel-belted radial tires, naturally, supply the road grip. They're 175/70R13, the fat, low-profile kind mounted on 5" steel wheels with chrome trim.

You'll see better with new halogen headlights. And dual side mirrors have inside controls (it may seem silly to have inside mirror controls on a convertible, but it does rain once in a while, right?)

Continuing with our visibility story, there also are front vent windows, an intermittent feature for the windshield wipers and — last-but-not least — a real glass window in the convertible top that's heated electrically.

Have we thought of everything? We think so. Take a demonstration drive and see for yourself.

\*1982 EPA (27) estimated mpg, 40 highway. Use estimated mpg for comparison to other cars.

Your actual mileage will vary with speed, weather and trip length. Highway mileage will probably be less.

**A.** The short-throw 5-speed stick shift fits into a console with voltmeter, oil pressure and temperature gauges.

**B.** You can step out of the Rabbit Convertible well-groomed thanks to a vanity mirror in the passenger's sun visor.

**C.** Windshield wiping system includes an intermittent position on the steering column lever. The wiper will sweep every six seconds, automatically improving visibility during a light drizzle.

**D.** Diamond Silver Metallic Rabbit Convertible with Black top.

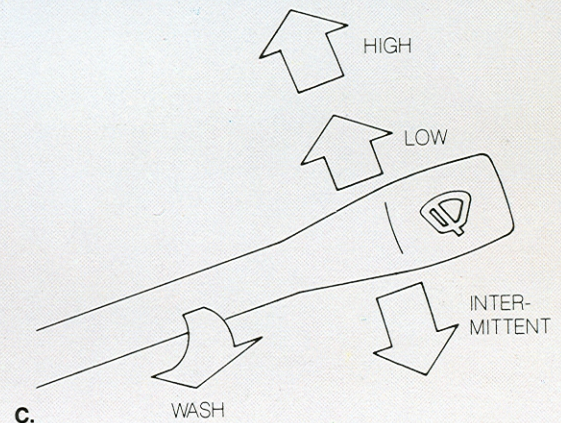
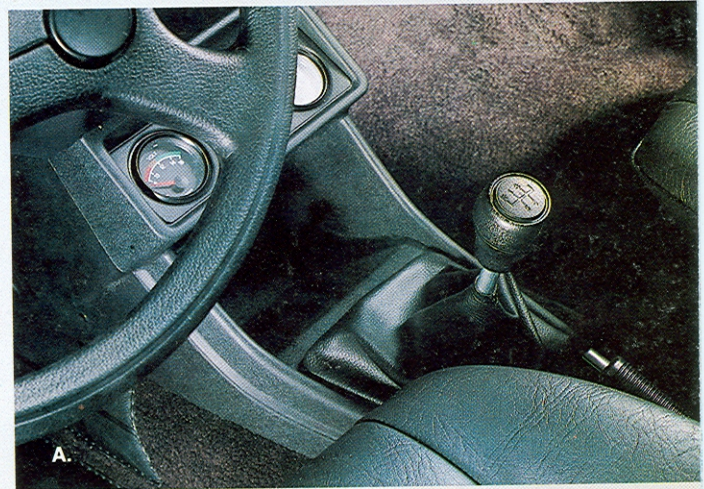

# YOU'RE ON THE WAY TO HAVING A GOOD TIME WHEN YOU

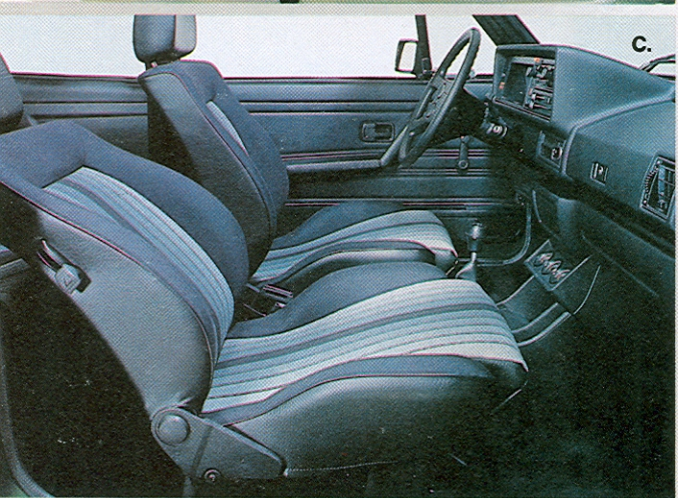
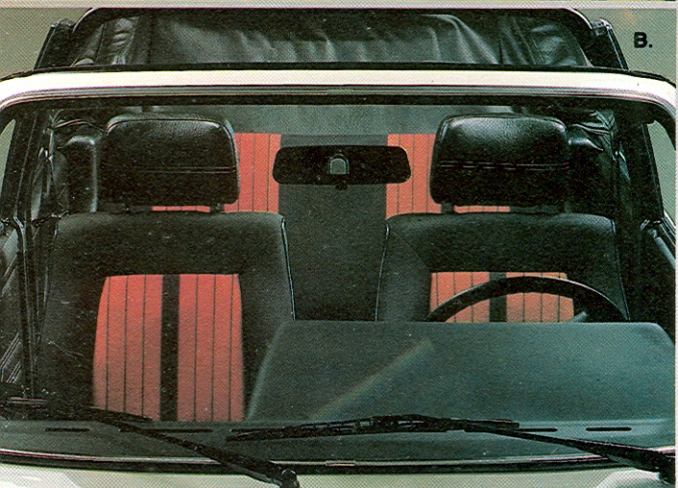
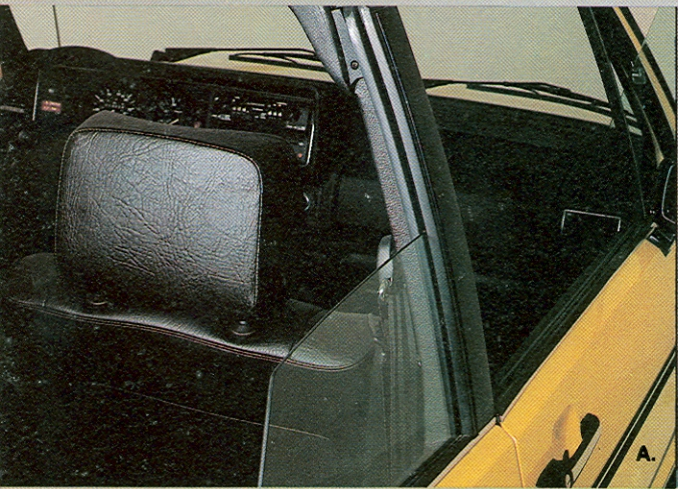

Few things in life are predictable, but a top-down ride — sunny day or starry night — guarantees smiles. Of course, you have to be in a proper environment. Which is why the Rabbit Convertible interior is so lavish.

The front bucket seats are fully adjustable, reclining and covered in attractive, but tough, leatherette. Or, order special cloth-upholstered sport seats with wraparound comfort.

A new stereo cassette radio is standard. It plays through front and rear speakers, or either set should you choose. Note that a dual-tone horn is included so you can hear it even with the stereo turned up.

More ambience is provided by plush carpeting that continues up the doors. The dash with a tach and digital clock is flanked by an oversized glove box. We suggest using it to store sun tan lotion and a hair brush — a vanity mirror in the right visor is on us.

You'll discover lots more about a Rabbit Convertible once you get over its obvious virtues, such as the locking gas cap and a light in the luggage compartment.

We want you to enjoy getting to where you want to be, but if it's not as much fun as your Rabbit, take the long way home.

---

**A.** The vertical section of the roll bar has channels to positively position the windows, as in a sedan.

**B. and C.** Reclining sport seats with wraparound comfort and distinctive striping are offered as optional equipment in black cloth with either a red or grey pattern.

**D.** Extensive reinforcements make the Rabbit Convertible nearly as strong as the sedan. An integral roll bar also helps keep the top aligned for better window sealing.

**E.** Alpine White Rabbit Convertible with Sand top.

---

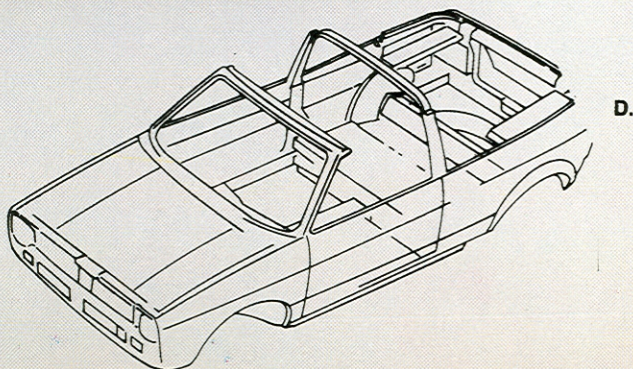

CAN ENJOY GETTING THERE.



E.

TO CONSIDER THE RABBIT CONVERTIBLE SERIOUSLY, IN



NEW REAR SEAT IS COMFORTABLE, TOO—SO THERE'S



IMAGINE YOURSELF IN THESE SPECIAL BUCKET SEATS.



WE'LL BE LESS OF A RUSH TO SEE WHO SITS UP FRONT.

# IF YOU'RE KNOWLEDGEABLE ABOUT CARS, YOU KNOW OR DO YOU?

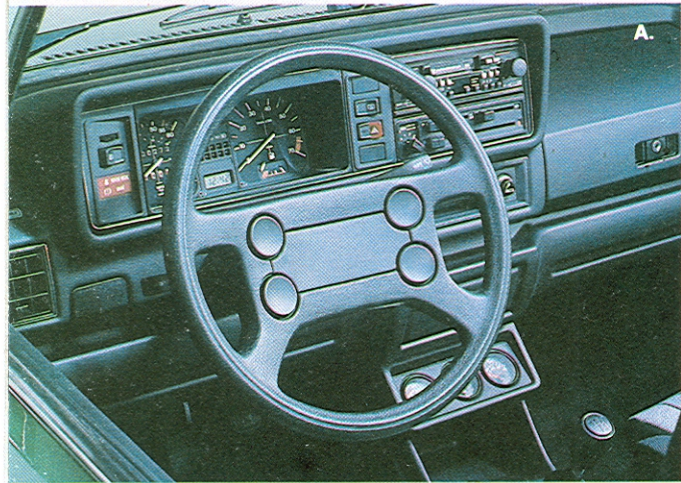

Oh sure, there are other convertibles around. And most automakers offer a sporty model, but the Rabbit Convertible stands alone.

For example, it's an excellent investment. That's right. Past year's models of the Rabbit Convertible have commanded a very high resale value.

Perhaps this value retention is because a used convertible is a rare commodity. In that case, rest assured that convertibles are not going out of style.

And consider that a Rabbit Convertible is backed by a nationwide Volkswagen dealer network recognized for outstanding service performance and parts availability.

These are traditional factors, along with quality of workmanship and durability, every bit as important to discerning car buyers as gas mileage and price. So don't think of the Rabbit Convertible as anything but an exceptional automobile — as, well, a Volkswagen.

If it wasn't a first-class car in every respect we wouldn't invite comparison, would we?

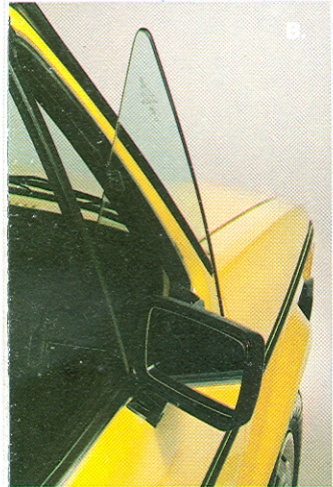

**A.** As with every Volkswagen, the Rabbit Convertible has instruments and operating controls carefully positioned for driving ease.

**B.** Standard equipment includes thoughtful details such as dual outside mirrors adjusted from the inside and front vent windows (for the top-down feeling with the top up).

**C.** A new AM/FM stereo cassette radio is standard in the Rabbit Convertible. You'll have to supply your own tapes.

**D.** MacPherson strut front suspension and rack and pinion steering, combined with front wheel drive, make the Rabbit Convertible responsive and easy to handle.

**E.** Lagos Yellow Rabbit Convertible with Black top.

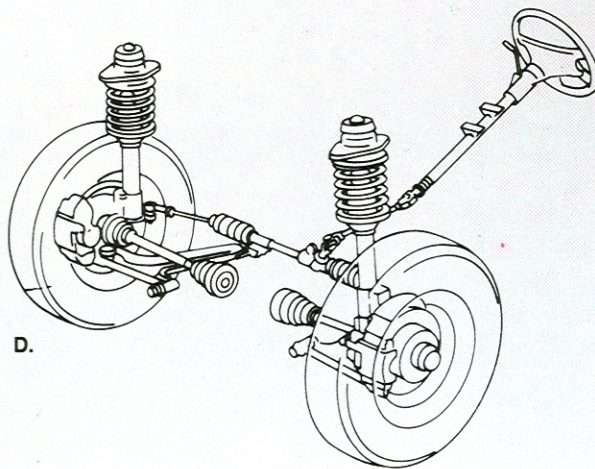
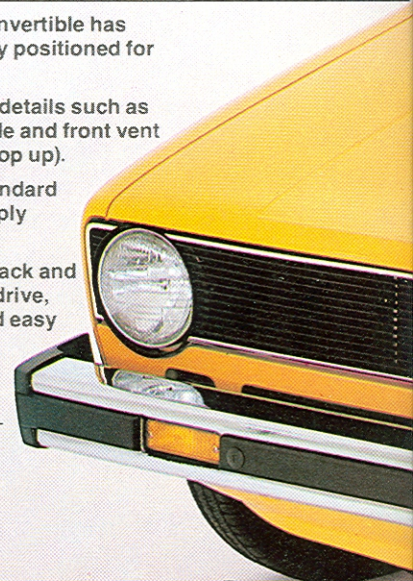

**E.**

**D.**

THE RABBIT CONVERTIBLE'S COMPETITORS.



THERE'S ANOTHER GERMAN CONVERTIBLE,



# THE MERCEDES IS ALSO BUILT WITH PAINSTAKING CARE.

It's true. The Rabbit Convertible and Mercedes convertible share the same limited-production status where quality of workmanship is paramount. Our car is crafted in the famous Karmann Coachworks facilities where the pace is slow, the detailing meticulous.

Both convertibles incorporate a layered top made virtually by hand. Ours is three layers thick with insulation for noise, heat or cold, as well as wetness and humidity. So you can effectively air condition your Rabbit Convertible to be comfortable whether it's muggy or too sunny.

Anyone looking closely can see that the Rabbit Convertible is built for the automotive connoisseur. It's also just as much of a status symbol — in its own way — as the other German convertible.

**A.** Even a car wash doesn't disturb the integrity of the Rabbit Convertible top. Its precise, careful fit virtually eliminates wind noise or boom.

**B.** The locking rear hatch cover lifts for access to the trunk, spare tire and the rear seatback release.

**C.** The Karmann Coachworks insignia marks every Rabbit Convertible. Optional alloy wheels add an extra touch.

**D.** Mars Red Rabbit Convertible with Black top.

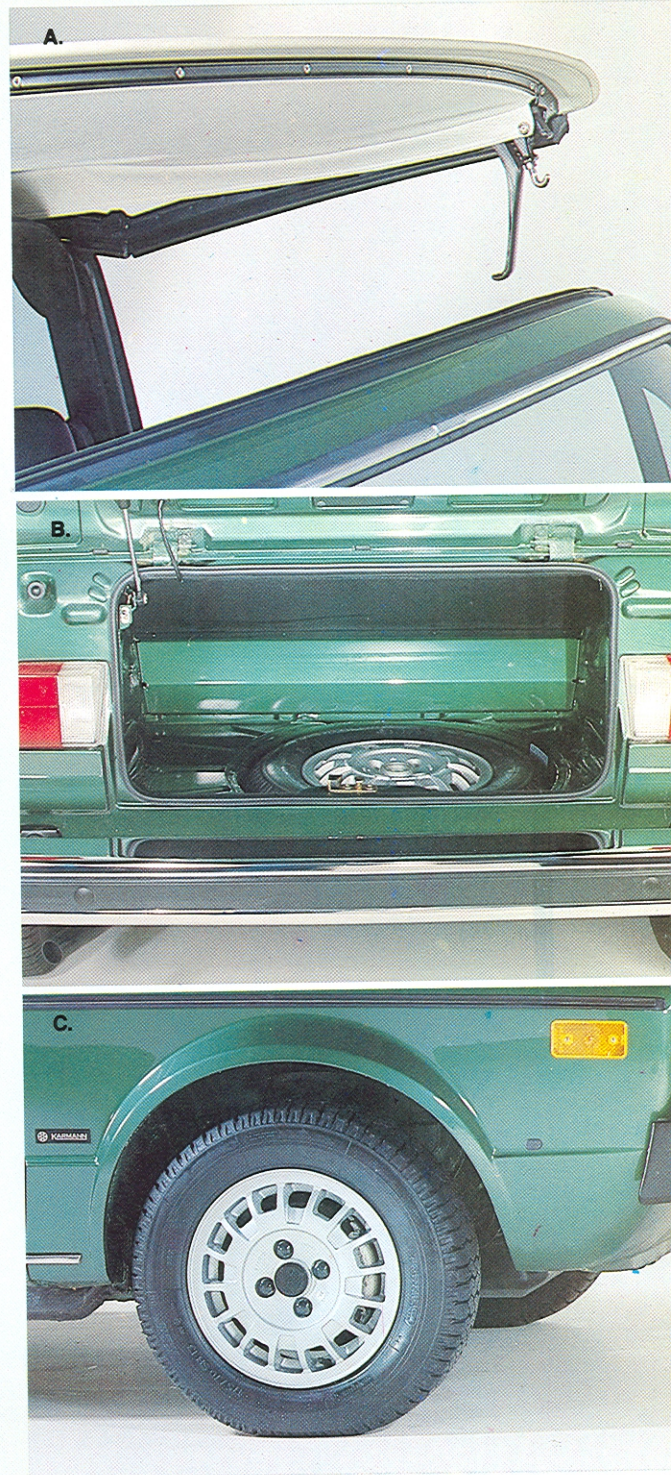
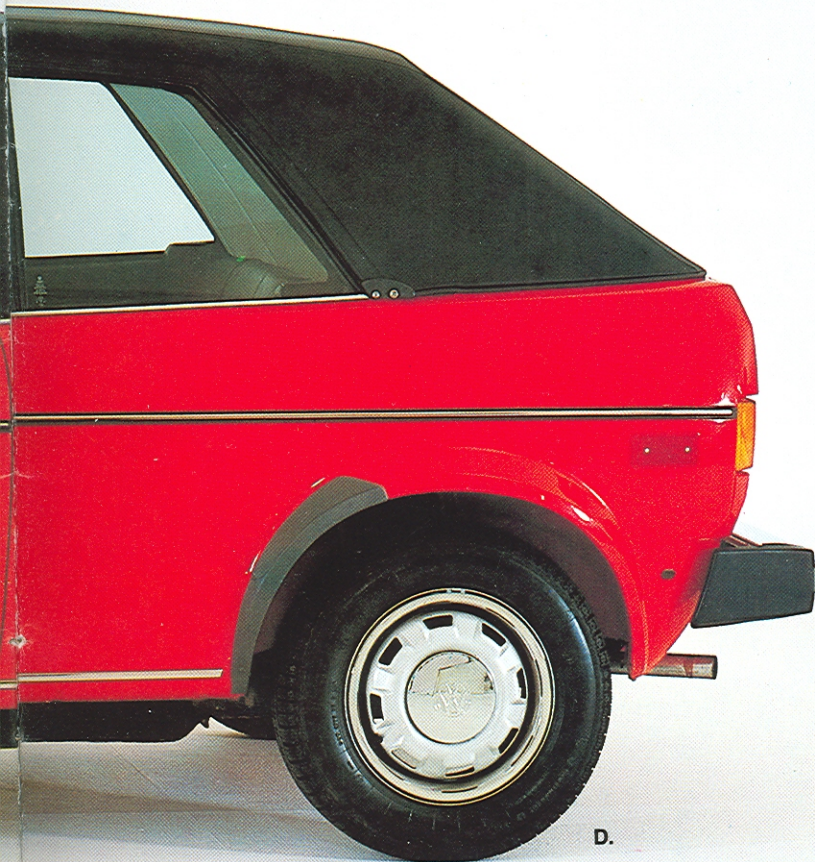



SAND  
METALLIC

CIRRUS GREY  
METALLIC

CEDAR GREEN  
METALLIC

SURINAM  
METALLIC

DIAMOND SILVER  
METALLIC

# 1982 RABBIT CONVERTIBLE SPECIFICATIONS



## RABBIT CONVERTIBLE EXTERIOR COLORS



MARS RED



ALPINE WHITE



LAGOS YELLOW

### BODY

#### DIMENSIONS AND CAPACITIES

Unit body/chassis construction featuring an integrated roll bar, bolt-on front fenders, two doors with folding soft top.

Length	155.3"
Wheelbase	94.5"
Width	63.4"
Height, unloaded	55.5"
Track, front/rear	54.7"/53.1"
Ground clearance, loaded	4.8"
Luggage capacity, (SAE cu. ft.)	6.0

### ENGINE

#### COOLING AND FUEL SYSTEMS

Four-cylinder transverse-mounted engine with cast iron block and aluminum alloy cylinder head, belt driven overhead camshaft. Water-cooled with pressurized, cross-flow radiator, thermostatically controlled radiator fan. Fuel tank capacity 10.6 gallons. Fuel-injected with metering valve controlling continuous flow to injectors at each intake valve. Unleaded gasoline required.

#### ENGINE SPECIFICATIONS

Bore x stroke, in.	3.13 x 3.40
Displacement, cu. in./cc.	105/1715
Compression ratio	8.2:1
Horsepower (SAE net) at rpm	74 at 5000
Torque (SAE net) foot pounds at rpm	89.6 at 3000

### ELECTRICAL SYSTEM

12 volt with 55 amp alternator, (45 amp/hr battery and breakerless transistorized ignition.

### DRIVE TRAIN

Front wheel drive with twin constant-velocity jointed drive axles. Single dry plate clutch. Fully-synchronized manual transmission incorporating an upshift indicator light.

#### TRANSMISSION RATIOS

	STANDARD 4+E MANUAL	OPTIONAL 3-SPEED AUTOMATIC
First	3.45:1	2.55:1
Second	1.94:1	1.45:1
Third	1.29:1	1.00:1
Fourth	.91:1	—
Fifth	.71:1	—
Reverse	3.17:1	2.46:1
Final drive	3.89:1	3.56:1

### STEERING SYSTEM

Maintenance-free rack and pinion with double pivot column. Ratio 20.8:1. Turning circle (curb to curb) 31.2'. Turns lock to lock 3.9.

### FRONT SUSPENSION

Independent MacPherson strut with coil springs and telescopic shock absorbers. Negative steering roll radius.

### REAR SUSPENSION

Independent stabilizer axle with trailing arms, coil springs and telescopic shock absorbers.

### BRAKE SYSTEM

Power-assisted with 9.4" front discs and 7.1" rear drums, self-adjusting. Dual diagonal hydraulic circuits. Mechanical handbrake on rear wheels.

### WHEELS AND TIRES

Rim size	5J x 13
Tire type	Steel-belted radial
Tire size	175/70R13

Volkswagen of America, Inc. believes the specifications in this brochure to be correct at the time of printing; however, specifications, standard equipment and options are subject to change without notice. Some options may be unavailable when your car is built. Please ask your dealer for advice concerning current availability of options and verify that your car includes the optional equipment you ordered.

**Jetta**  
**Rabbit &**  
**Convertible**  
**Scirocco**

**Nothing else**  
**is a Volkswagen.**

**Quantum**  
**Vanagon &**  
**Camper**  
**Pickup**